

# WATER SAFE®

## ASSEMBLY INSTRUCTIONS for FA Model Enclosures

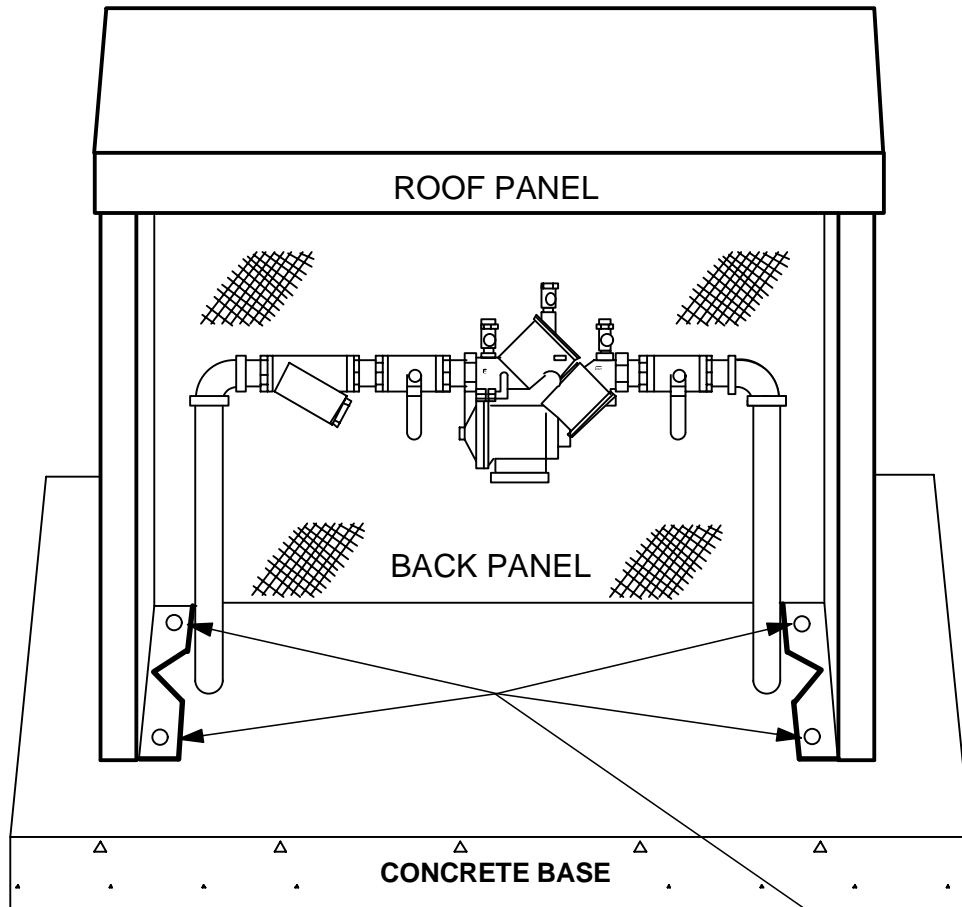

### FRONT ELEVATION VIEW

1. Center a minimum 4" thick concrete base around the installed device placing expansion material around the riser pipes.

2. Center the enclosure around the device as shown above.  
**NOTE :** The test ports must face the access opening on devices with side ports.

3. Drill 1/4" holes in concrete using the holes in the enclosure base as a guide. Insert anchor bolts and tighten hex nuts (4 places). **NOTE: CHECK ACCESS OPENING CLEARANCE AT BOTTOM BEFORE DRILLING HOLES.**

4. Set access panel and lock in place.

