

# ROLL TOP™ ASSEMBLY INSTRUCTIONS

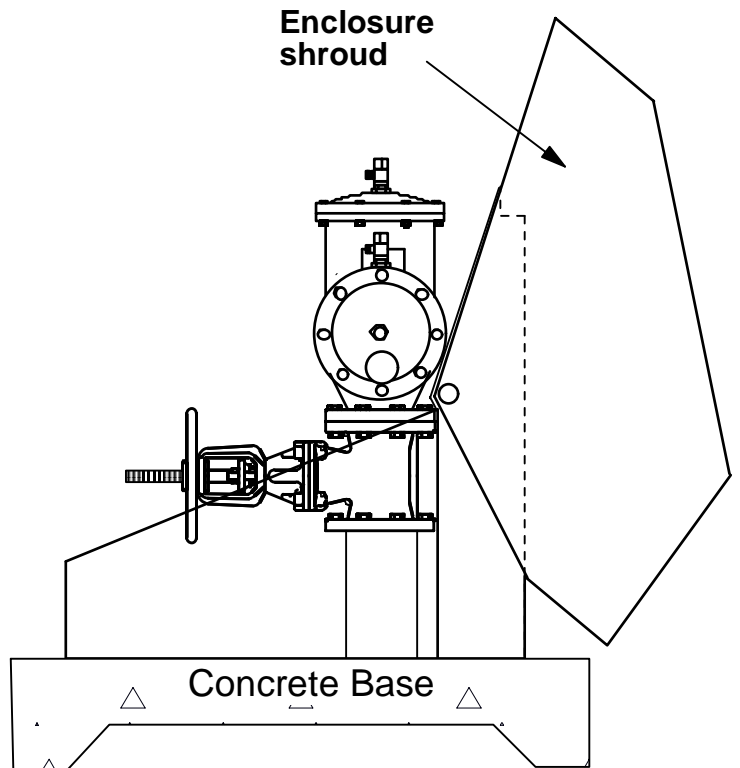
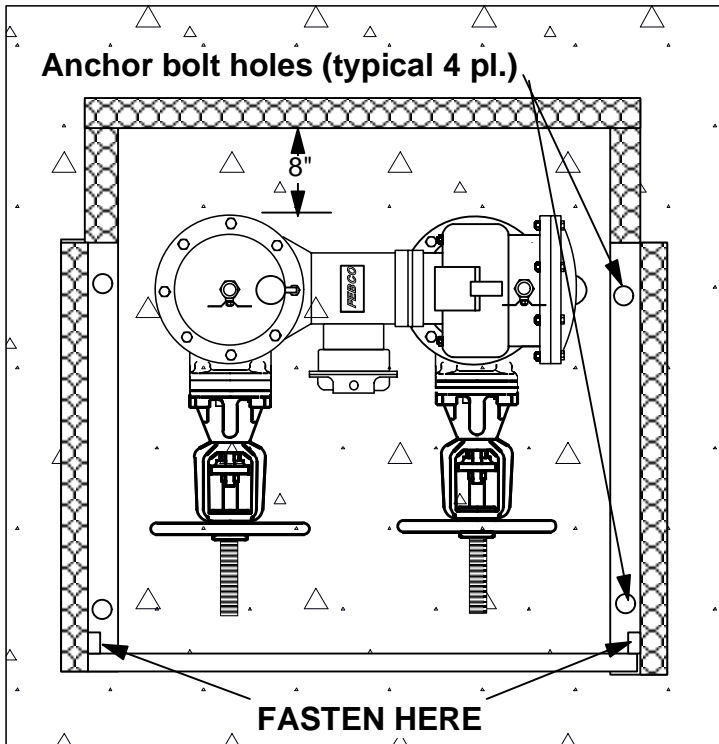

1. Center a minimum 6" thick concrete base around the installed device placing expansion material around risers. Place conduit (before concrete pour) when installing a CLASS I enclosure (heat required).

2. Open enclosure shroud and remove the four (4) stainless fasteners at front drain panel. Slide enclosure around the device and reinstall front drain panel. (NOTE: 3/8" hex driver furnished). Carefully close the enclosure shroud to insure proper clearance around the device. Reopen enclosure and drill 1/4" holes in concrete with masonry bit using holes in enclosure base as a guide. Insert stainless steel anchor bolts and tighten hex nuts. (NOTE: 1/4" masonry bit furnished).

3. Close and lock enclosure shroud.

4. For CLASS I enclosures; follow ALL local and national electrical codes.

